

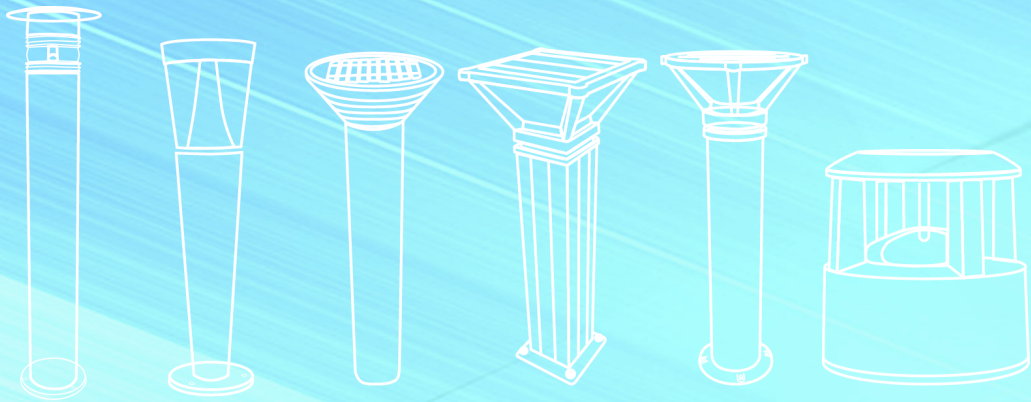

Solar Light Manufacture

SOLAR LAWN LAMP



THINK BRIGHT, THINK SOLUX

WWW.SOLUX-LIGHT.COM
CONTACT@SOLUX-LIGHT.COM

SL-021 SOLAR LAWN LAMP

0\$ ELECTRICITY CONSUMPTION - 0\$ COST
OF TRENCHING - 0\$ CABLING

Solux
Solar Light Manufacture



- 23 HOURS AUTONOMY**
SMART POWER MANAGEMENT
4 RAINY DAYS BACK UP
- LIFEPO4 BATTERY**
LITHIUM LIFEPO4 BATTERY
LIFETIME UP TO 12 YEARS
WORKING TEMP -15°+65°
- AUTOMATIC OPERATION**
DAY & NIGHT DETECTION
AUTOMATIC POWER
ON & OFF
- LED LIGHTING**
HIGH BRIGHTNESS LED
36 PIECES OF 0.09W EACH
50000 HOURS LIFE SPAM
- SOLAR PANEL**
4.5W MONOCRYSTALLINE
SOLAR PANEL
GRADE A SOLAR CELLS
- DIE CASTING ALUMINIUM**
AKZONOBEL PAINTING
COROSION RESISTANT
- ENVIRONMENT**
GREEN ENERGY:
0 CARBONE DIOXIDE
EMISSIONS
- WATER PROOF**
IP 65
COMPLIANT

CE IEC ISO IP 65 RoHS **5 YEAR WARRANTY**

TECHNICAL SPECIFICATIONS

LED POWER: 3.5 WATTS	MATERIAL: ALUMINIUM
BATTERY: 4.5 AH 6.4V	LUMENS: 425 LUMENS
PV PANEL: 4.5 WATTS GRADE A	AUTONOMY: 23 HOURS
CHARGING: 6 HOURS / DAY	WARRANTY: 5 YEARS

BRIGHTNESS: 3.5W = 20W = 85W CCT: 3000-6500K

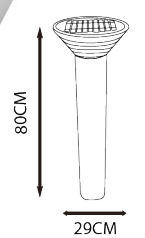

WWW.SOLUX-LIGHT.COM
CONTACT@SOLUX-LIGHT.COM

SL-014

SOLAR LAWN LAMP

0\$ ELECTRICITY CONSUMPTION - 0\$ COST
OF TRENCHING - 0\$ CABLING

Solux
Solar Light Manufacture

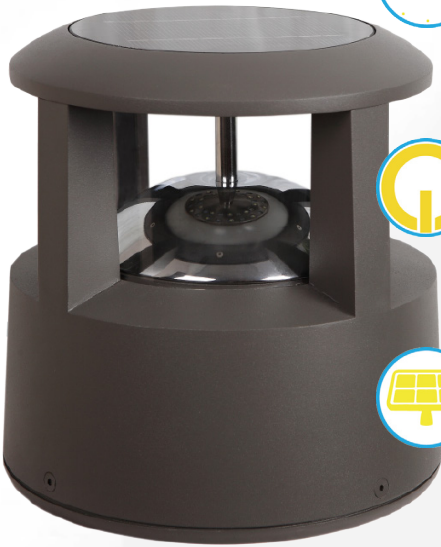

23 HOURS AUTONOMY



SMART POWER MANAGEMENT
4 RAINY DAYS BACK UP

LIFEPO4 BATTERY



LITHIUM LIFEPO4 BATTERY
LIFETIME UP TO 12 YEARS
WORKING TEMP -15°+65°

AUTOMATIC OPERATION



DAY & NIGHT DETECTION
AUTOMATIC POWER
ON & OFF

LED LIGHTING



HIGH BRIGHTNESS LED
18 PIECES OF 0.09W EACH
50000 HOURS LIFE SPAN

SOLAR PANEL



3.5W MONOCRYSTALLINE
SOLAR PANEL
GRADE A SOLAR CELLS

DIE CASTING ALUMINIUM



AKZONOBEL PAINTING
CORROSION RESISTANT

ENVIRONMENT



GREEN ENERGY:
0 CARBONE DIOXIDE
EMISSIONS

WATER PROOF



IP 65
COMPLIANT



TECHNICAL SPECIFICATIONS

LED POWER: 1.8 WATTS	MATERIAL: ALUMINIUM
BATTERY: 4.5 AH 6.4V	LUMENS: 250 LUMENS
PV PANEL: 3.5 WATTS GRADE A	AUTONOMY: 23 HOURS
CHARGING: 6 HOURS / DAY	WARRANTY: 5 YEARS
BRIGHTNESS: 1.8W = 10W = 42W CCT: 3000-6500K	

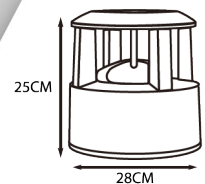

WWW.SOLUX-LIGHT.COM
CONTACT@SOLUX-LIGHT.COM

SL-015 SOLAR LAWN LAMP

0\$ ELECTRICITY CONSUMPTION - 0\$ COST
OF TRENCHING - 0\$ CABLING

Solux
Solar Light Manufacture



23 HOURS AUTONOMY

SMART POWER MANAGEMENT
4 RAINY DAYS BACK UP



LIFEPO4 BATTERY

LITHIUM LIFEPO4 BATTERY
LIFETIME UP TO 12 YEARS
WORKING TEMP -15°+65°



AUTOMATIC OPERATION

DAY & NIGHT DETECTION
AUTOMATIC POWER
ON & OFF



LED LIGHTING

HIGH BRIGHTNESS LED
18 PIECES OF 0.09W EACH
50000 HOURS LIFE SPAN



SOLAR PANEL

3.5W MONOCRYSTALLINE
SOLAR PANEL
GRADE A SOLAR CELLS



DIE CASTING ALUMINIUM

AKZONOBEL PAINTING
CORROSION RESISTANT



ENVIRONMENT

GREEN ENERGY:
0 CARBONE DIOXIDE
EMISSIONS



WATER PROOF

IP 65
COMPLIANT



RoHS



TECHNICAL SPECIFICATIONS

LED POWER: 1.8 WATTS

MATERIAL: ALUMINIUM

BATTERY: 4.5 AH 6.4V

LUMENS: 250 LUMENS

PV PANEL: 3.5 WATTS GRADE A

AUTONOMY: 23 HOURS

CHARGING: 6 HOURS / DAY

WARRANTY: 5 YEARS

BRIGHTNESS: 1.8W  = 10W  = 42W  CCT: 3000-6500K

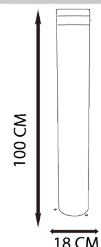

WWW.SOLUX-LIGHT.COM
CONTACT@SOLUX-LIGHT.COM

SL-016 SOLAR LAWN LAMP

0\$ ELECTRICITY CONSUMPTION - 0\$ COST
OF TRENCHING - 0\$ CABLING

Solux
Solar Light Manufacture



23 HOURS AUTONOMY



SMART POWER MANAGEMENT
4 RAINY DAYS BACK UP

LIFEPO4 BATTERY



LITHIUM LIFEPO4 BATTERY
LIFETIME UP TO 12 YEARS
WORKING TEMP -15°+65°

AUTOMATIC OPERATION



DAY & NIGHT DETECTION
AUTOMATIC POWER
ON & OFF

LED LIGHTING



HIGH BRIGHTNESS LED
28 PIECES OF 0.09W EACH
50000 HOURS LIFE SPAM

SOLAR PANEL



3.5W MONOCRYSTALLINE
SOLAR PANEL
GRADE A SOLAR CELLS

DIE CASTING ALUMINIUM



AKZONOBEL PAINTING
COROSION RESISTANT

ENVIRONMENT



GREEN ENERGY:
0 CARBONE DIOXIDE
EMISSIONS

WATER PROOF



IP 65
COMPLIANT



RoHS



TECHNICAL SPECIFICATIONS

LED POWER: 2.5 WATTS

MATERIAL: ALUMINIUM

BATTERY: 4.5 AH 6.4V

LUMENS: 320 LUMENS

PV PANEL: 3.5 WATTS GRADE A

AUTONOMY: 23 HOURS

CHARGING: 6 HOURS / DAY

WARRANTY: 5 YEARS

BRIGHTNESS: 2.5W  =14W  =58W  CCT: 3000-6500K

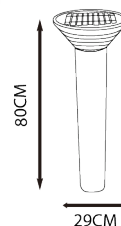

WWW.SOLUX-LIGHT.COM
CONTACT@SOLUX-LIGHT.COM

SL-018 SOLAR LAWN LAMP

0\$ ELECTRICITY CONSUMPTION - 0\$ COST
OF TRENCHING - 0\$ CABLING

Solux
Solar Light Manufacture



23 HOURS AUTONOMY

SMART POWER MANAGEMENT
4 RAINY DAYS BACK UP



LIFEPO4 BATTERY

LITHIUM LIFEPO4 BATTERY
LIFETIME UP TO 12 YEARS
WORKING TEMP -15°+65°



AUTOMATIC OPERATION

DAY & NIGHT DETECTION
AUTOMATIC POWER
ON & OFF



LED LIGHTING

HIGH BRIGHTNESS LED
36 PIECES OF 0.09W EACH
50000 HOURS LIFE SPAN



SOLAR PANEL

3.5W MONOCRYSTALLINE
SOLAR PANEL
GRADE A SOLAR CELLS



DIE CASTING ALUMINIUM

AKZONOBEL PAINTING
CORROSION RESISTANT



ENVIRONMENT

GREEN ENERGY:
0 CARBONE DIOXIDE
EMISSIONS



WATER PROOF

IP 65
COMPLIANT



RoHS



TECHNICAL SPECIFICATIONS

LED POWER: 3.5 WATTS

MATERIAL: ALUMINIUM

BATTERY: 4.5 AH 6.4V

LUMENS: 425 LUMENS

PV PANEL: 3.5 WATTS GRADE A

AUTONOMY: 23 HOURS

CHARGING: 6 HOURS / DAY

WARRANTY: 5 YEARS

BRIGHTNESS: 3.5W  =20W  =85W  CCT: 3000-6500K

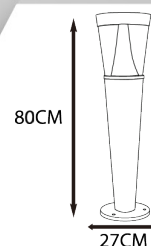









WWW.SOLLUX-LIGHT.COM
CONTACT@SOLLUX-LIGHT.COM

SL-005 SOLAR LAWN LAMP

0\$ ELECTRICITY CONSUMPTION - 0\$ COST
OF TRENCHING - 0\$ CABLING

Solux
Solar Light Manufacture





- 23 HOURS AUTONOMY**

SMART POWER MANAGEMENT
 4 RAINY DAYS BACK UP
- LIFEPO4 BATTERY**

LITHIUM LIFEPO4 BATTERY
 LIFETIME UP TO 12 YEARS
 WORKING TEMP -15°+65°
- AUTOMATIC OPERATION**

DAY & NIGHT DETECTION
 AUTOMATIC POWER
 ON & OFF
- LED LIGHTING**

HIGH BRIGHTNESS LED
 44 PIECES OF 0.09W EACH
 50000 HOURS LIFE SPAN
- SOLAR PANEL**

7W MONOCRYSTALLINE
SOLAR PANEL
 GRADE A SOLAR CELLS
- DIE CASTING ALUMINIUM**

AKZONOBEL PAINTING
 CORROSION RESISTANT
- ENVIRONMENT**

GREEN ENERGY:
 0 CARBONE DIOXIDE
 EMISSIONS
- WATER PROOF**

IP 65
 COMPLIANT





RoHS

TECHNICAL SPECIFICATIONS

LED POWER: 4 WATTS	MATERIAL: ALUMINIUM
BATTERY: 2*4.5 AH 6.4V	LUMENS: 500 LUMENS
PV PANEL: 7 WATTS GRADE A	AUTONOMY: 23 HOURS
CHARGING: 6 HOURS / DAY	WARRANTY: 5 YEARS
BRIGHTNESS: 4W  = 35W  = 110W  CCT: 3000-6500K	

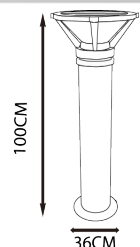

WWW.SOLUX-LIGHT.COM
CONTACT@SOLUX-LIGHT.COM

SL-006

SOLAR LAWN LAMP

0\$ ELECTRICITY CONSUMPTION - 0\$ COST
OF TRENCHING - 0\$ CABLING

Solux
Solar Light Manufacture



23 HOURS AUTONOMY



SMART POWER MANAGEMENT
4 RAINY DAYS BACK UP

LIFEPO4 BATTERY



LITHIUM LIFEPO4 BATTERY
LIFETIME UP TO 12 YEARS
WORKING TEMP -15°+65°

AUTOMATIC OPERATION



DAY & NIGHT DETECTION
AUTOMATIC POWER
ON & OFF

LED LIGHTING



HIGH BRIGHTNESS LED
44 PIECES OF 0.09W EACH
50000 HOURS LIFE SPAN

SOLAR PANEL



7W MONOCRYSTALLINE
SOLAR PANEL
GRADE A SOLAR CELLS

DIE CASTING ALUMINIUM



AKZONOBEL PAINTING
CORSION RESISTANT

ENVIRONMENT



GREEN ENERGY:
0 CARBONE DIOXIDE
EMISSIONS

WATER PROOF



IP 65
COMPLIANT

CE IEC ISO IP65 RoHS **5 YEAR WARRANTY**

TECHNICAL SPECIFICATIONS

LED POWER: 4 WATTS	MATERIAL: ALUMINIUM
BATTERY: 2*4.5 AH 6.4V	LUMENS: 500 LUMENS
PV PANEL: 7 WATTS GRADE A	AUTONOMY: 23 HOURS
CHARGING: 6 HOURS / DAY	WARRANTY: 5 YEARS

BRIGHTNESS: 4W = 35W = 110W CCT: 3000-6500K

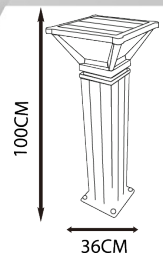

WWW.SOLUX-LIGHT.COM
CONTACT@SOLUX-LIGHT.COM

SL-002 SOLAR LAWN LAMP

0\$ ELECTRICITY CONSUMPTION - 0\$ COST
OF TRENCHING - 0\$ CABLING

Solux
Solar Light Manufacture



23 HOURS AUTONOMY



SMART POWER MANAGEMENT
4 RAINY DAYS BACK UP

LIFEPO4 BATTERY



LITHIUM LIFEPO4 BATTERY
LIFETIME UP TO 12 YEARS
WORKING TEMP -15°+65°

AUTOMATIC OPERATION



DAY & NIGHT DETECTION
AUTOMATIC POWER
ON & OFF

LED LIGHTING



HIGH BRIGHTNESS LED
18 PIECES OF 0.09W EACH
50000 HOURS LIFE SPAN

SOLAR PANEL



3.5W MONOCRYSTALLINE
SOLAR PANEL
GRADE A SOLAR CELLS

DIE CASTING ALUMINIUM



AKZONOBEL PAINTING
COROSION RESISTANT

ENVIRONMENT



GREEN ENERGY:
0 CARBONE DIOXIDE
EMISSIONS

WATER PROOF





IP 65
COMPLIANT



RoHS



TECHNICAL SPECIFICATIONS

LED POWER: 1.8 WATTS	MATERIAL: ALUMINIUM
BATTERY: 4.5 AH 6.4V	LUMENS: 250 LUMENS
PV PANEL: 3.5 WATTS GRADE A	AUTONOMY: 23 HOURS
CHARGING: 6 HOURS / DAY	WARRANTY: 5 YEARS
BRIGHTNESS: 1.8W  = 10W  = 42W  CCT: 3000-6500K	

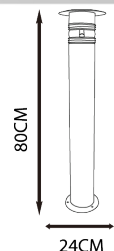

WWW.SOLUX-LIGHT.COM
CONTACT@SOLUX-LIGHT.COM

SL-012

SOLAR LAWN LAMP

0\$ ELECTRICITY CONSUMPTION - 0\$ COST
OF TRENCHING - 0\$ CABLING

Solux
Solar Light Manufacture



23 HOURS AUTONOMY

SMART POWER MANAGEMENT
4 RAINY DAYS BACK UP



LIFEPO4 BATTERY

LITHIUM LIFEPO4 BATTERY
LIFETIME UP TO 12 YEARS
WORKING TEMP -15°+65°



AUTOMATIC OPERATION

DAY & NIGHT DETECTION
AUTOMATIC POWER
ON & OFF



LED LIGHTING

HIGH BRIGHTNESS LED
18 PIECES OF 0.09W EACH
50 000 HOURS LIFE SPAN



SOLAR PANEL

3.5W MONOCRYSTALLINE
SOLAR PANEL
GRADE A SOLAR CELLS



DIE CASTING ALUMINIUM

AKZONOBEL PAINTING
CORROSION RESISTANT



ENVIRONMENT

GREEN ENERGY:
0 CARBONE DIOXIDE
EMISSIONS



WATER PROOF

IP 65
COMPLIANT



RoHS



TECHNICAL SPECIFICATIONS

LED POWER: 1.8 WATTS

MATERIAL: ALUMINIUM

BATTERY: 4.5 AH 6.4V

LUMENS: 250 LUMENS

PV PANEL: 3.5 WATTS GRADE A

AUTONOMY: 23 HOURS

CHARGING: 6 HOURS / DAY

WARRANTY: 5 YEARS

BRIGHTNESS: 1.8W  = 10W  = 42W  CCT: 3000-6500K

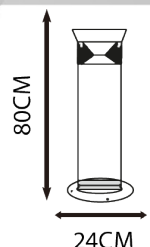

WWW.SOLUX-LIGHT.COM
CONTACT@SOLUX-LIGHT.COM

SL-019

SOLAR LAWN LAMP

0\$ ELECTRICITY CONSUMPTION - 0\$ COST
OF TRENCHING - 0\$ CABLING

Solux
Solar Light Manufacture



23 HOURS AUTONOMY



SMART POWER MANAGEMENT
4 RAINY DAYS BACK UP

LIFEPO4 BATTERY



LITHIUM LIFEPO4 BATTERY
LIFETIME UP TO 12 YEARS
WORKING TEMP - 15°+65°

AUTOMATIC OPERATION



DAY & NIGHT DETECTION
AUTOMATIC POWER
ON & OFF

LED LIGHTING



HIGH BRIGHTNESS LED
36 PIECES OF 0.09W EACH
50000 HOURS LIFE SPAN

SOLAR PANEL



3.5W MONOCRYSTALLINE
SOLAR PANEL
GRADE A SOLAR CELLS

DIE CASTING ALUMINIUM



AKZONOBEL PAINTING
COROSION RESISTANT

ENVIRONMENT



GREEN ENERGY:
0 CARBONE DIOXIDE
EMISSIONS

WATER PROOF



IP 65
COMPLIANT



TECHNICAL SPECIFICATIONS

LED POWER: 3.5 WATTS	MATERIAL: ALUMINIUM
BATTERY: 4.5 AH 6.4V	LUMENS: 425 LUMENS
PV PANEL: 3.5 WATTS GRADE A	AUTONOMY: 23 HOURS
CHARGING: 6 HOURS / DAY	WARRANTY: 5 YEARS

BRIGHTNESS: 3.5W =20W =85W CCT: 3000-6500K

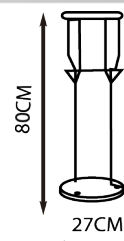

WWW.SOLUX-LIGHT.COM
CONTACT@SOLUX-LIGHT.COM

BW-021 SOLAR LAWN LAMP

0\$ ELECTRICITY CONSUMPTION - 0\$ COST
OF TRENCHING - 0\$ CABLING

Solux
Solar Light Manufacture



23 HOURS AUTONOMY

SMART POWER MANAGEMENT
4 RAINY DAYS BACK UP



LIFEPO4 BATTERY

LITHIUM LIFEPO4 BATTERY
LIFETIME UP TO 12 YEARS
WORKING TEMP - 15°+65°



AUTOMATIC OPERATION

DAY & NIGHT DETECTION
AUTOMATIC POWER
ON & OFF



LED LIGHTING

HIGH BRIGHTNESS LED
36 PIECES OF 0.09W EACH
50000 HOURS LIFE SPAN



SOLAR PANEL

4.5W MONOCRYSTALLINE
SOLAR PANEL
GRADE A SOLAR CELLS



DIE CASTING ALUMINIUM

AKZONOBEL PAINTING
CORROSION RESISTANT



ENVIRONMENT

GREEN ENERGY:
0 CARBONE DIOXIDE
EMISSIONS



WATER PROOF

IP 65
COMPLIANT



RoHS



TECHNICAL SPECIFICATIONS

LED POWER: 3.5 WATTS

MATERIAL: ALUMINIUM

BATTERY: 4.5 AH 6.4V

LUMENS: 425 LUMENS

PV PANEL: 4.5 WATTS GRADE A

AUTONOMY: 23 HOURS

CHARGING: 6 HOURS / DAY

WARRANTY: 5 YEARS

BRIGHTNESS: 3.5W  =20W  =85W  CCT: 3000-6500K

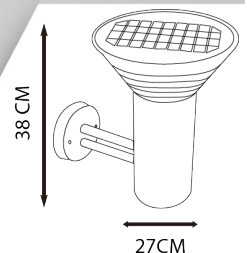

WWW.SOLUX-LIGHT.COM
CONTACT@SOLUX-LIGHT.COM

ALL IN ONE

INTEGRATED SOLAR STREET LIGHT

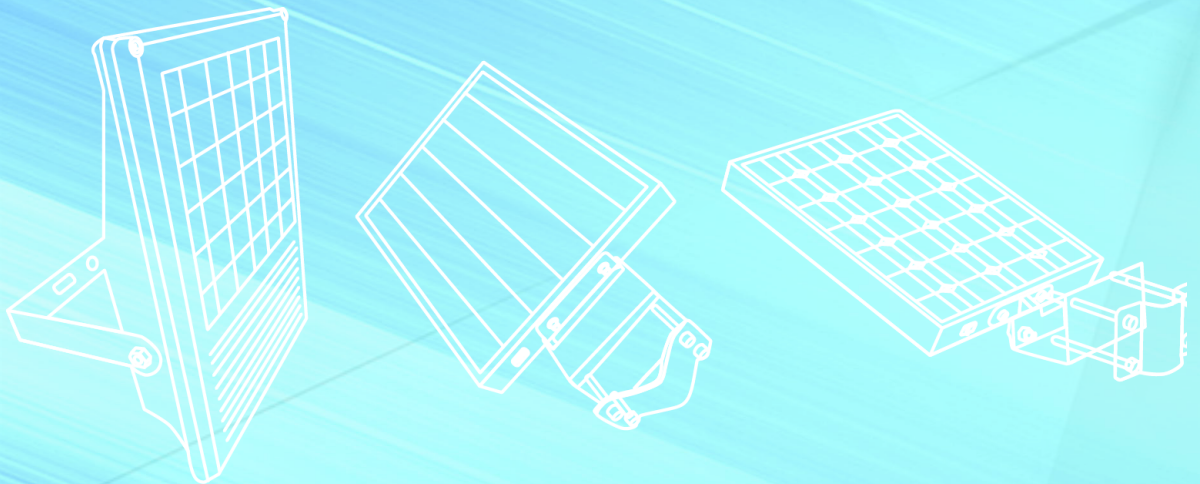

THINK BRIGHT, THINK SOLUX

WWW.SOLUX-LIGHT.COM
CONTACT@SOLUX-LIGHT.COM

AOS 5 ALL IN ONE

0\$ ELECTRICITY CONSUMPTION - 0\$ COST
OF TRENCHING - 0\$ CABLING

Solux
Solar Light Manufacture



23 HOURS AUTONOMY

SMART POWER MANAGEMENT 4
RAINY DAYS BACK UP



LIFEPO4 BATTERY

2*4.5AH GELL CELL DEEP
CYCLE BATTERY SPECIALLY
CUSTOMIZED FOR
SOLAR APPLICATION



AUTOMATIC OPERATION

DAY & NIGHT DETECTION
AUTOMATIC POWER
ON & OFF



LED LIGHTING

5W HIGH EFFICIENCY LED



SOLAR PANEL

8W MONOCRYSTALLINE
SOLAR PANEL
GRADE A SOLAR CELLS



DIE CASTING ALUMINIUM

AKZONOBEL PAINTING
CORROSION RESISTANT



ENVIRONMENT

GREEN ENERGY:
0 CARBONE DIOXIDE
EMISSIONS



WATER PROOF

IP 65
COMPLIANT



RoHS



TECHNICAL SPECIFICATIONS

LED POWER: 5 WATTS

MATERIAL: ALUMINIUM

BATTERY: 2*4.5 AH 6.4V

LUMENS: 700 LUMENS

PV PANEL: 8 WATTS GRADE A

AUTONOMY: 23 HOURS

CHARGING: 6 HOURS / DAY

WARRANTY: 3 YEARS

BRIGHTNESS: 5W



= 25W



= 115W

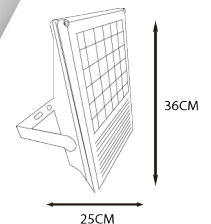

WWW.SOLUX-LIGHT.COM
CONTACT@SOLUX-LIGHT.COM

AOS 8 ALL IN ONE

0\$ ELECTRICITY CONSUMPTION - 0\$ COST
OF TRENCHING - 0\$ CABLING

Solux
Solar Light Manufacture

SOLAR PANEL

18W MONOCRYSTALLINE
SOLAR PANEL
WE USE ONLY GRADE A
SOLAR CELLS

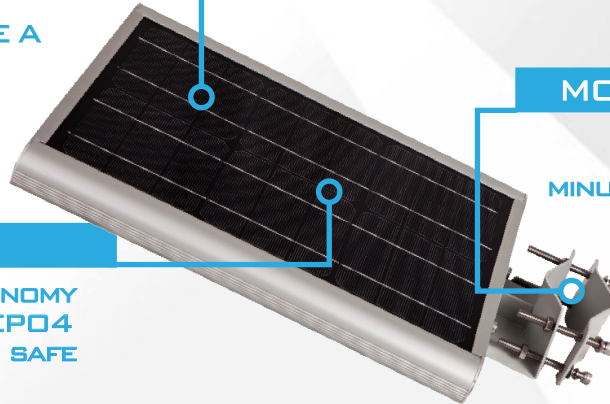

MOUNTING SYSTEM

READY TO USE,
INSTALLATION IN 30
MINUTES OR LESS ON WALL OR
POLE



ANTI THEFT SCREWS

BATTERY

MORE THAN 24H AUTONOMY
WITH LITHIUM 6AH LIFEPO4
BATTERY INSIDE. 100% SAFE
NO EXPLOSION RISKS

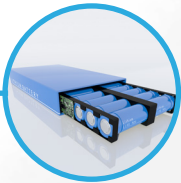

LED PHILIPS LUXEON

8 WATTS HIGH EFFICIENCY LED

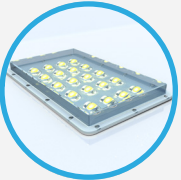

PHILIPS

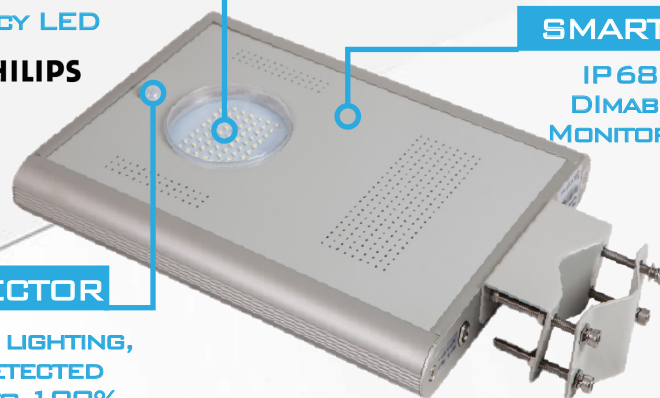

SMART CONTROLLER

IP68 SMART CONTROLLER,
DIMABLE, REMOTE CONTROL
MONITORING, LED & BATTERY
PROTECTION



PIR SENSOR DETECTOR

50% LIGHT PERMANENT LIGHTING,
WHEN PRESENCE IS DETECTED
LIGHTING POWER TURN TO 100%.
(CUSTOMIZABLE)

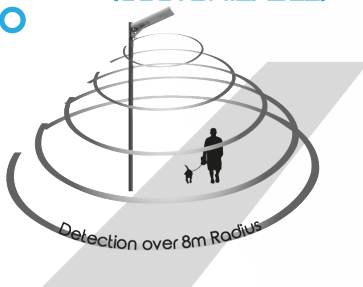

WWW.SOLUX-LIGHT.COM
CONTACT@SOLUX-LIGHT.COM

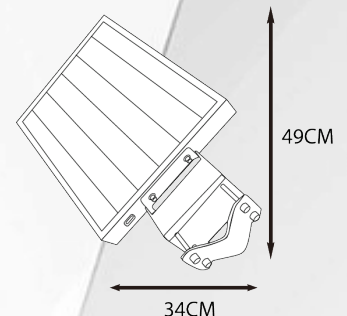

TECHNICAL SPECIFICATIONS

3
YEAR
WARRANTY

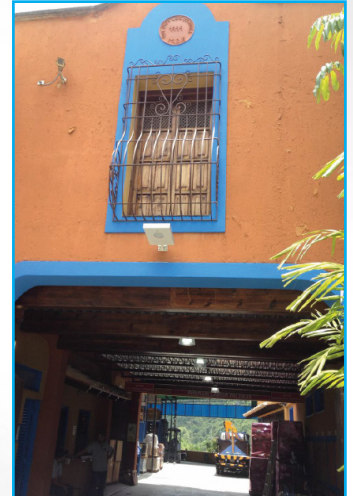

WATTS LUMENS
8 **880**

TECHNICAL SPECIFICATIONS

MODEL:	AOS-5 (WITH SENSOR)	MOUNTING HEIGHT (M):	3-4 M
SOLAR PANEL:	18V/18W GRADE A SOLAR CELLS	SPACE BETWEEN LIGHT(M):	8-10 M
BATTERY TYPE:	LITHIUM LIFEPO4 6 AH 12.8V	LAMP MATERIAL:	ALUMINIUM ALLOY
LED MAX POWER:	12V/8WATTS	WARRANTY PERIOD:	3 YEARS
LED CHIP BRAND:	PHILIPS LUXEON	UNIT SIZE:	505*275*70MM
LUMEN (LM):	800-880 LUMENS	N.W:	5 KG
LED LIFE TIME:	OVER 50000 HOURS	CARTON SIZE:	580*380*130MM
LIGHTING VIEWING ANGLE:	120°	Q'TY/CTN:	4 SET/ CTN
CHARGE TIME (BY SUN):	6-7 HOURS	GW FOR CARTON:	24,73 KG
DISCHARGE TIME:	OVER 20 HOURS (SAVING MODE)	20 GP CONTAINER:	888 SETS
WORKING TEMP (C°):	-20 °C TO +60 °C	40 GP CONTAINER:	1604 SETS

WWW.SOLUX-LIGHT.COM
CONTACT@SOLUX-LIGHT.COM

AOS 15 ALL IN ONE

0\$ ELECTRICITY CONSUMPTION - 0\$ COST
OF TRENCHING - 0\$ CABLING

Solux
Solar Light Manufacture

SOLAR PANEL

25W MONOCRYSTALLINE
SOLAR PANEL
WE USE ONLY GRADE A
SOLAR CELLS

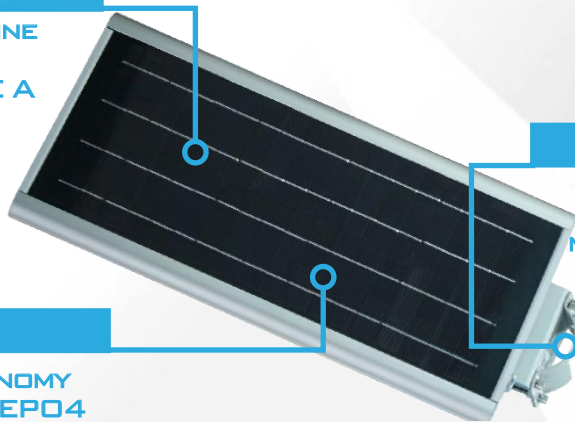

MOUNTING SYSTEM

READY TO USE,
INSTALLATION IN 30
MINUTES OR LESS ON WALL OR
POLE



ANTI THEFT SCREWS

BATTERY

MORE THAN 24H AUTONOMY
WITH LITHIUM 10AH LIFEPO4
BATTERY INSIDE. 100% SAFE
NO EXPLOSION RISKS

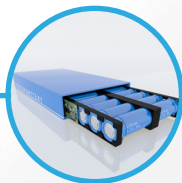

LED PHILIPS LUXEON

15 WATTS HIGH EFFICIENCY LED

PHILIPS

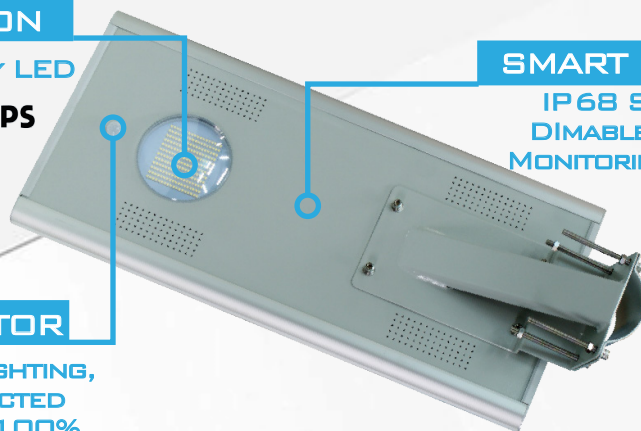

SMART CONTROLLER

IP68 SMART CONTROLLER,
DIMABLE, REMOTE CONTROL
MONITORING, LED & BATTERY
PROTECTION



PIR SENSOR DETECTOR

50% LIGHT PERMANENT LIGHTING,
WHEN PRESENCE IS DETECTED
LIGHTING POWER TURN TO 100%.
(CUSTOMIZABLE)

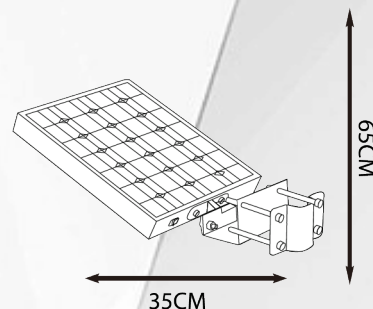
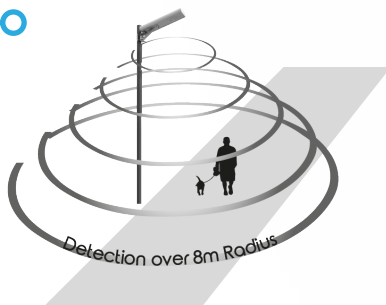

WWW.SOLUX-LIGHT.COM
CONTACT@SOLUX-LIGHT.COM

TECHNICAL SPECIFICATIONS

3
YEAR
WARRANTY



WATTS LUMENS
15 1650

CE IEC ISO IP65 RoHS

TECHNICAL SPECIFICATIONS

MODEL:	AOS-15 (WITH SENSOR)	MOUNTING HEIGHT(M):	4-5 M
SOLAR PANEL:	18V/25W GRADE A SOLAR CELLS	SPACE BETWEEN LIGHT(M):	10-15 M
BATTERY TYPE:	LITHIUM LIFEPO4 10AH 12.8V	LAMP MATERIAL:	ALUMINIUM ALLOY
LED MAX POWER:	12V/15WATTS	WARRANTY PERIOD:	3 YEARS
LED CHIP BRAND:	PHILIPS LUXEON	UNIT SIZE:	745*325*140MM
LUMEN (LM):	1500-1650 LUMENS	N.W:	8 KG
LED LIFE TIME:	OVER 50000 HOURS	CARTON SIZE:	815*380*200MM
LIGHTING VIEWING ANGLE: 120°		Q'TY/CTN:	1 SET/ CTN
CHARGE TIME (BY SUN):	6-7 HOURS	GW FOR CARTON:	9,5 KG
DISCHARGE TIME:	OVER 20 HOURS (SAVING MODE)	20 GP CONTAINER:	305 SETS
WORKING TEMP (C°):	-20°C TO +60°C	40 GP CONTAINER:	635 SETS

WWW.SOLUX-LIGHT.COM
CONTACT@SOLUX-LIGHT.COM

AOS 20 ALL IN ONE

0\$ ELECTRICITY CONSUMPTION - 0\$ COST
OF TRENCHING - 0\$ CABLING

Solux
Solar Light Manufacture

SOLAR PANEL

50W MONOCRYSTALLINE
SOLAR PANEL
WE USE ONLY GRADE A
SOLAR CELLS

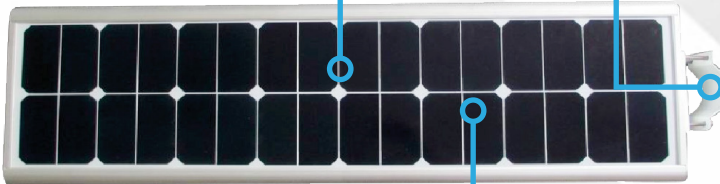

MOUNTING SYSTEM

READY TO USE,
INSTALLATION IN 30
MINUTES OR LESS ON WALL OR
POLE



ANTI THEFT SCREWS

BATTERY

MORE THAN 24H AUTONOMY
WITH LITHIUM 18AH LIFEPO4
BATTERY INSIDE. 100% SAFE
NO EXPLOSION RISKS



SMART CONTROLLER

IP68 SMART CONTROLLER,
DIMABLE, REMOTE CONTROL
MONITORING, LED & BATTERY
PROTECTION

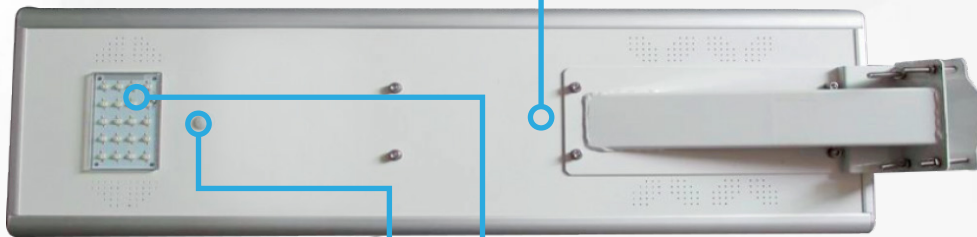

PIR SENSOR DETECTOR

50% LIGHT PERMANENT LIGHTING,
WHEN PRESENCE IS DETECTED
LIGHTING POWER TURN TO 100%.
(CUSTOMIZABLE)

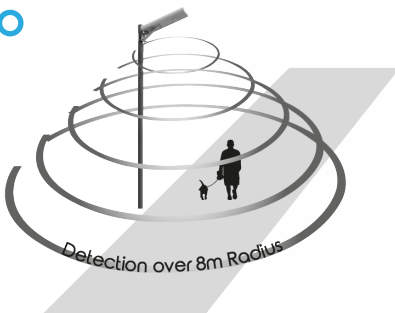

LED PHILIPS LUXEON

20 WATTS HIGH EFFICIENCY LED

PHILIPS

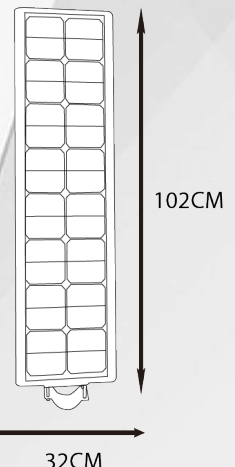

WWW.SOLUX-LIGHT.COM
CONTACT@SOLUX-LIGHT.COM

TECHNICAL SPECIFICATIONS

3
YEAR
WARRANTY

WATTS LUMENS
20 2600

CE IEC ISO IP65 RoHS



TECHNICAL SPECIFICATIONS

MODEL:	AOS-20 (WITH SENSOR)	MOUNTING HEIGHT(M):	5-6 M
SOLAR PANEL:	18V/50W GRADE A SOLAR CELLS	SPACE BETWEEN LIGHT(M):	18-20 M
BATTERY TYPE:	LITHIUM LIFEPO4 18AH 12.8V	LAMP MATERIAL:	ALUMINIUM ALLOY
LED MAX POWER:	12V/20WATTS	WARRANTY PERIOD:	3 YEARS
LED CHIP BRAND:	PHILIPS LUXEON	UNIT SIZE:	1140*330*140MM
LUMEN (LM):	2400-2600 LUMENS	N.W:	16 KG
LED LIFE TIME:	OVER 50000 HOURS	CARTON SIZE:	1170*375*200MM
LIGHTING VIEWING ANGLE: 120°		Q'TY/CTN:	1 SET/ CTN
CHARGE TIME (BY SUN):	6-7 HOURS	GW FOR CARTON:	17,4 KG
DISCHARGE TIME:	OVER 20 HOURS (SAVING MODE)	20 GP CONTAINER:	270 SETS
WORKING TEMP (C°):	-20°C TO +60°C	40 GP CONTAINER:	550 SETS

WWW.SOLUX-LIGHT.COM
CONTACT@SOLUX-LIGHT.COM

AOS 30 ALL IN ONE

0\$ ELECTRICITY CONSUMPTION - 0\$ COST
OF TRENCHING - 0\$ CABLING

Solux
Solar Light Manufacture

SOLAR PANEL

60W MONOCRYSTALLINE
SOLAR PANEL
WE USE ONLY GRADE A
SOLAR CELLS

MOUNTING SYSTEM

READY TO USE,
INSTALLATION IN 30
MINUTES OR LESS ON WALL OR
POLE



ANTI THEFT SCREWS

BATTERY

MORE THAN 24H AUTONOMY
WITH LITHIUM 21AH LIFEPO4
BATTERY INSIDE. 100% SAFE
NO EXPLOSION RISKS

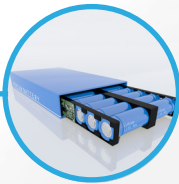

SMART CONTROLLER

IP68 SMART CONTROLLER,
DIMABLE, REMOTE CONTROL
MONITORING, LED & BATTERY
PROTECTION



PIR SENSOR DETECTOR

50% LIGHT PERMANENT LIGHTING,
WHEN PRESENCE IS DETECTED
LIGHTING POWER TURN TO 100%.
(CUSTOMIZABLE)

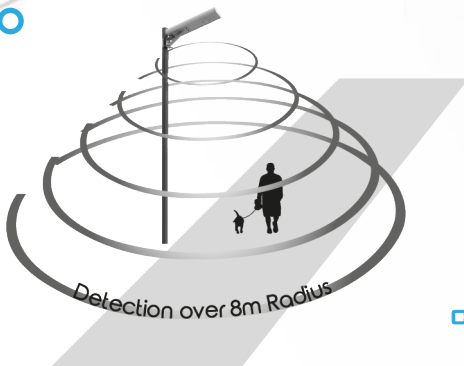

LED PHILIPS LUXEON

30 WATTS HIGH EFFICIENCY LED

PHILIPS



WWW.SOLUX-LIGHT.COM
CONTACT@SOLUX-LIGHT.COM

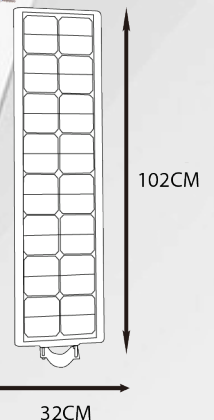

TECHNICAL SPECIFICATIONS

3
YEAR
WARRANTY



WATTS LUMENS
30 3900



TECHNICAL SPECIFICATIONS

MODEL:	AOS-30 (WITH SENSOR)	MOUNTING HEIGHT (M):	6-7 M
SOLAR PANEL:	18V/60W GRADE A SOLAR CELLS	SPACE BETWEEN LIGHT(M):	20-25 M
BATTERY TYPE:	LITHIUM LIFEPO4 21 AH 12.8V	LAMP MATERIAL:	ALUMINIUM ALLOY
LED MAX POWER:	12V/30WATTS	WARRANTY PERIOD:	3 YEARS
LED CHIP BRAND:	PHILIPS LUXEON	UNIT SIZE:	1140*330*140MM
LUMEN (LM):	3600-3900 LUMENS	N.W:	16,2 KG
LED LIFE TIME:	OVER 50000 HOURS	CARTON SIZE:	1170*375*200MM
LIGHTING VIEWING ANGLE:	120°	Q'TY/CTN:	1 SET / CTN
CHARGE TIME (BY SUN):	6-7 HOURS	GW FOR CARTON:	17,5 KG
DISCHARGE TIME:	OVER 20 HOURS (SAVING MODE)	20 GP CONTAINER:	270 SETS
WORKING TEMP (C°):	-20°C TO +60°C	40 GP CONTAINER:	550 SETS

WWW.SOLUX-LIGHT.COM
CONTACT@SOLUX-LIGHT.COM

AOS 40 ALL IN ONE

0\$ ELECTRICITY CONSUMPTION - 0\$ COST
OF TRENCHING - 0\$ CABLING

Solux
Solar Light Manufacture

SOLAR PANEL

65W MONOCRYSTALLINE
SOLAR PANEL
WE USE ONLY GRADE A
SOLAR CELLS

MOUNTING SYSTEM

READY TO USE,
INSTALLATION IN 30
MINUTES OR LESS ON WALL OR
POLE



ANTI THEFT SCREWS

BATTERY

MORE THAN 24H AUTONOMY
WITH LITHIUM 25AH LIFEPO4
BATTERY INSIDE. 100% SAFE
NO EXPLOSION RISKS



SMART CONTROLLER

IP68 SMART CONTROLLER,
DIMABLE, REMOTE CONTROL
MONITORING, LED & BATTERY
PROTECTION



PIR SENSOR DETECTOR

50% LIGHT PERMANENT LIGHTING,
WHEN PRESENCE IS DETECTED
LIGHTING POWER TURN TO 100%.
(CUSTOMIZABLE)

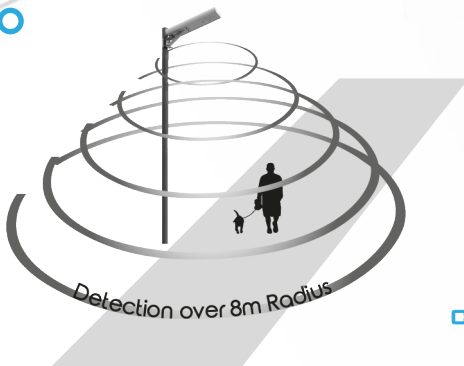

LED PHILIPS LUXEON

40 WATTS HIGH EFFICIENCY LED

PHILIPS

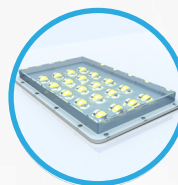

WWW.SOLUX-LIGHT.COM
CONTACT@SOLUX-LIGHT.COM

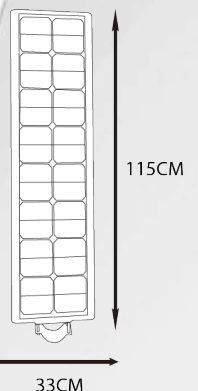

TECHNICAL SPECIFICATIONS

3
YEAR
WARRANTY



WATTS
40

LUMENS
5200

TECHNICAL SPECIFICATIONS

MODEL:	AOS-40 (WITH SENSOR)	MOUNTING HEIGHT (M):	7-8 M
SOLAR PANEL:	18V/65W GRADE A SOLAR CELLS	SPACE BETWEEN LIGHT (M):	22-26 M
BATTERY TYPE:	LITHIUM LIFEPO4 25AH 12.8V	LAMP MATERIAL:	ALUMINIUM ALLOY
LED MAX POWER:	12V/40WATTS	WARRANTY PERIOD:	3 YEARS
LED CHIP BRAND:	PHILIPS LUXEON	UNIT SIZE:	1140*330*140MM
LUMEN (LM):	4800-5200 LUMENS	N.W:	17,1 KG
LED LIFE TIME:	OVER 50000 HOURS	CARTON SIZE:	1170*375*200MM
LIGHTING VIEWING ANGLE: 120°		Q'TY/CTN:	1 SET / CTN
CHARGE TIME (BY SUN):	6-7 HOURS	GW FOR CARTON:	18,6 KG
DISCHARGE TIME:	OVER 20 HOURS (SAVING MODE)	20 GP CONTAINER:	270 SETS
WORKING TEMP (C°):	-20°C TO +60°C	40 GP CONTAINER:	550 SETS

WWW.SOLUX-LIGHT.COM
CONTACT@SOLUX-LIGHT.COM

AOS 60 ALL IN ONE

0\$ ELECTRICITY CONSUMPTION - 0\$ COST
OF TRENCHING - 0\$ CABLING

Solux
Solar Light Manufacture

SOLAR PANEL

120W MONOCRYSTALLINE
SOLAR PANEL
WE USE ONLY GRADE A
SOLAR CELLS

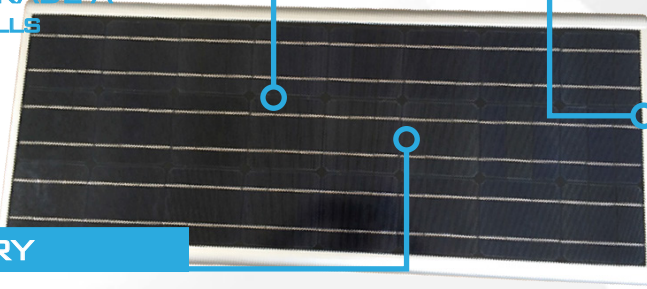

MOUNTING SYSTEM

READY TO USE,
INSTALLATION IN 30
MINUTES OR LESS ON WALL OR
POLE



ANTI THEFT SCREWS

BATTERY

MORE THAN 24H AUTONOMY
WITH LITHIUM 42AH LIFEPO4
BATTERY INSIDE. 100% SAFE
NO EXPLOSION RISKS



SMART CONTROLLER

IP68 SMART CONTROLLER,
DIMABLE, REMOTE CONTROL
MONITORING, LED & BATTERY
PROTECTION



PIR SENSOR DETECTOR

50% LIGHT PERMANENT LIGHTING,
WHEN PRESENCE IS DETECTED
LIGHTING POWER TURN TO 100%.
(CUSTOMIZABLE)

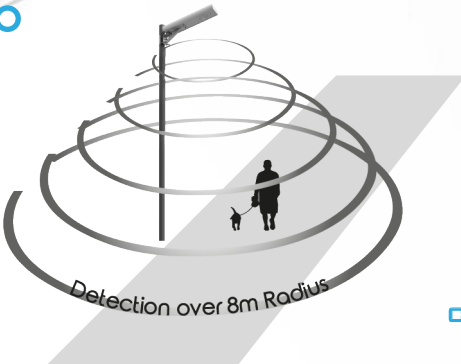

LED PHILIPS LUXEON

60 WATTS HIGH EFFICIENCY LED

PHILIPS

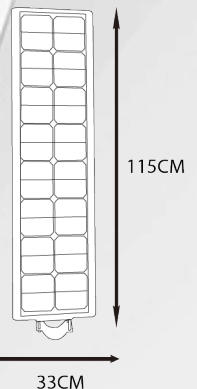
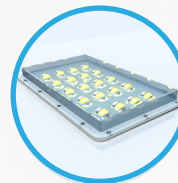

WWW.SOLUX-LIGHT.COM
CONTACT@SOLUX-LIGHT.COM

TECHNICAL SPECIFICATIONS

3
YEAR
WARRANTY



WATTS
60

LUMENS
9000



TECHNICAL SPECIFICATIONS

MODEL:	AOS-60 (WITH SENSOR)	MOUNTING HEIGHT (M):	9-10 M
SOLAR PANEL:	18V/120W GRADE A SOLAR CELLS	SPACE BETWEEN LIGHT(M):	24-29 M
BATTERY TYPE:	LITHIUM LIFEPO4 42 AH 12.8V	LAMP MATERIAL:	ALUMINIUM ALLOY
LED MAX POWER:	12V/60WATTS	WARRANTY PERIOD:	3 YEARS
LED CHIP BRAND:	PHILIPS LUXEON	UNIT SIZE:	1078*525*140MM
LUMEN (LM):	7800-9000 LUMENS	N.W:	24 KG
LED LIFE TIME:	OVER 50000 HOURS	CARTON SIZE:	1185*580*200MM
LIGHTING VIEWING ANGLE:	120°	Q'TY/CTN:	1 SET/ CTN
CHARGE TIME (BY SUN):	6-7 HOURS	GW FOR CARTON:	24,8 KG
DISCHARGE TIME:	OVER 20 HOURS (SAVING MODE)	20 GP CONTAINER:	200 SETS
WORKING TEMP (C°):	-20 °C TO +60 °C	40 GP CONTAINER:	420 SETS

WWW.SOLUX-LIGHT.COM
CONTACT@SOLUX-LIGHT.COM

AOS 80 ALL IN ONE

0\$ ELECTRICITY CONSUMPTION - 0\$ COST
OF TRENCHING - 0\$ CABLING

Solux
Solar Light Manufacture

SOLAR PANEL

130 W MONOCRYSTALLINE
SOLAR PANEL
WE USE ONLY GRADE A
SOLAR CELLS

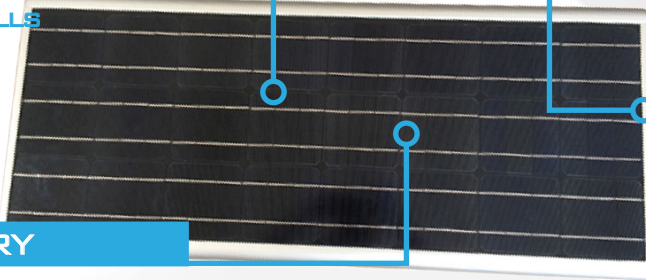

MOUNTING SYSTEM

READY TO USE,
INSTALLATION IN 30
MINUTES OR LESS ON WALL OR
POLE



ANTI THEFT SCREWS

BATTERY

MORE THAN 24H AUTONOMY
WITH LITHIUM 54AH LIFEPO4
BATTERY INSIDE. 100% SAFE
NO EXPLOSION RISKS



SMART CONTROLLER

IP68 SMART CONTROLLER,
DIMABLE, REMOTE CONTROL
MONITORING, LED & BATTERY
PROTECTION



PIR SENSOR DETECTOR

50% LIGHT PERMANENT LIGHTING,
WHEN PRESENCE IS DETECTED
LIGHTING POWER TURN TO 100%.
(CUSTOMIZABLE)



LED PHILIPS LUXEON

80 WATTS HIGH EFFICIENCY LED

PHILIPS

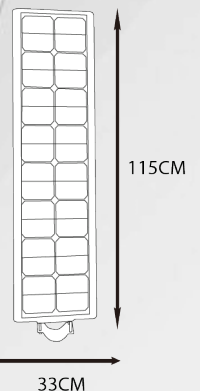

WWW.SOLUX-LIGHT.COM
CONTACT@SOLUX-LIGHT.COM

TECHNICAL SPECIFICATIONS

3
YEAR
WARRANTY



WATTS
80

LUMENS
10 500



TECHNICAL SPECIFICATIONS

MODEL:	AOS-80 (WITH SENSOR)	MOUNTING HEIGHT (M):	9- 10 M
SOLAR PANEL:	18V/130W GRADE A SOLAR CELLS	SPACE BETWEEN LIGHT(M):	24- 29 M
BATTERY TYPE:	LITHIUM LIFEPO4 54AH 12.8V	LAMP MATERIAL:	ALUMINIUM ALLOY
LED MAX POWER:	12V/80WATTS	WARRANTY PERIOD:	3 YEARS
LED CHIP BRAND:	PHILIPS LUXEON	UNIT SIZE:	1550*450*140MM
LUMEN (LM):	10 000-10 500 LUMENS	N.W:	30 KG
LED LIFE TIME:	OVER 50000 HOURS	CARTON SIZE:	1657*505*200MM
LIGHTING VIEWING ANGLE: 120°		Q'TY/CTN:	1 SET / CTN
CHARGE TIME (BY SUN):	7-8 HOURS	GW FOR CARTON:	31,5 KG
DISCHARGE TIME:	24 HOURS	20 GP CONTAINER:	170 SETS
WORKING TEMP (C°):	-20°C TO +60°C	40 GP CONTAINER:	380 SETS

WWW.SOLUX-LIGHT.COM
CONTACT@SOLUX-LIGHT.COM

AOS 100 ALL IN ONE

0\$ ELECTRICITY CONSUMPTION - 0\$ COST
OF TRENCHING - 0\$ CABLING

Solux
Solar Light Manufacture

SOLAR PANEL

140W MONOCRYSTALLINE
SOLAR PANEL
WE USE ONLY GRADE A
SOLAR CELLS

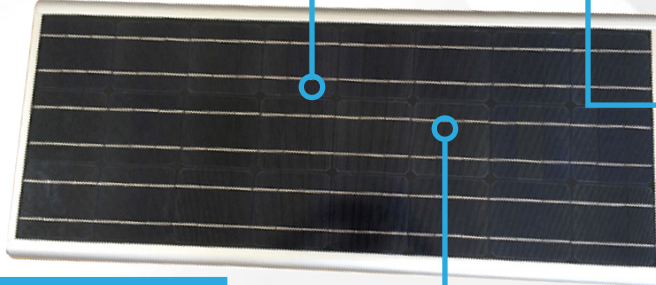

MOUNTING SYSTEM

READY TO USE,
INSTALLATION IN 30
MINUTES OR LESS ON WALL OR
POLE



ANTI THEFT SCREWS

BATTERY

MORE THAN 24H AUTONOMY
WITH LITHIUM 56AH LIFEPO4
BATTERY INSIDE. 100% SAFE
NO EXPLOSION RISKS



SMART CONTROLLER

IP68 SMART CONTROLLER,
DIMABLE, REMOTE CONTROL
MONITORING, LED & BATTERY
PROTECTION



PIR SENSOR DETECTOR

50% LIGHT PERMANENT LIGHTING,
WHEN PRESENCE IS DETECTED
LIGHTING POWER TURN TO 100%.
(CUSTOMIZABLE)

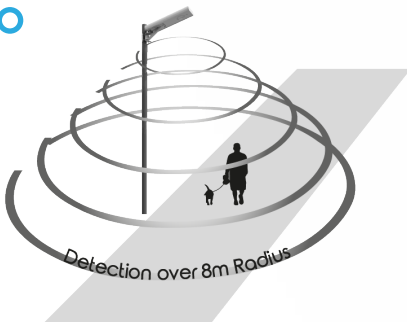

LED PHILIPS LUXEON

100 WATTS HIGH EFFICIENCY LED

PHILIPS



WWW.SOLUX-LIGHT.COM
CONTACT@SOLUX-LIGHT.COM

TECHNICAL SPECIFICATIONS

3
YEAR
WARRANTY



WATTS
100

LUMENS
13 000



TECHNICAL SPECIFICATIONS

MODEL:	AOS-100 (WITH SENSOR)	MOUNTING HEIGHT(M):	10- 12 M
SOLAR PANEL:	18V/140W GRADE A SOLAR CELLS	SPACE BETWEEN LIGHT(M):	24- 29 M
BATTERY TYPE:	LITHIUM LIFEPO4 56 AH 12.8V	LAMP MATERIAL:	ALUMINIUM ALLOY
LED MAX POWER:	12V/100WATTS	WARRANTY PERIOD:	3 YEARS
LED CHIP BRAND:	PHILIPS LUXEON	UNIT SIZE:	1550*450*140MM
LUMEN (LM):	12500-13000 LUMENS	N.W:	30 KG
LED LIFE TIME:	OVER 50000 HOURS	CARTON SIZE:	1657*505*200MM
LIGHTING VIEWING ANGLE: 120°		Q'TY/CTN:	1 SET/ CTN
CHARGE TIME (BY SUN):	6-7 HOURS	GW FOR CARTON:	31,5 KG
DISCHARGE TIME:	OVER 20 HOURS (SAVING MODE)	20 GP CONTAINER:	200 SETS
WORKING TEMP (C°):	-20°C TO +60°C	40 GP CONTAINER:	420 SETS

WWW.SOLUX-LIGHT.COM
CONTACT@SOLUX-LIGHT.COM

PHOTOMETRIC STUDIES

Solux
Solar Light Manufacture

YOUR PROJECT IS A CHALLENGE FOR US.

WE ARE ABLE TO ADVISE WITH:

- PERSONALISED LIGHTING STUDIES
- LIGHTING CALCULATIONS
- FLOOR PLANS WITH THE LIGHTING LAY OUT
- TECHNICAL REPORT/ESTIMATE

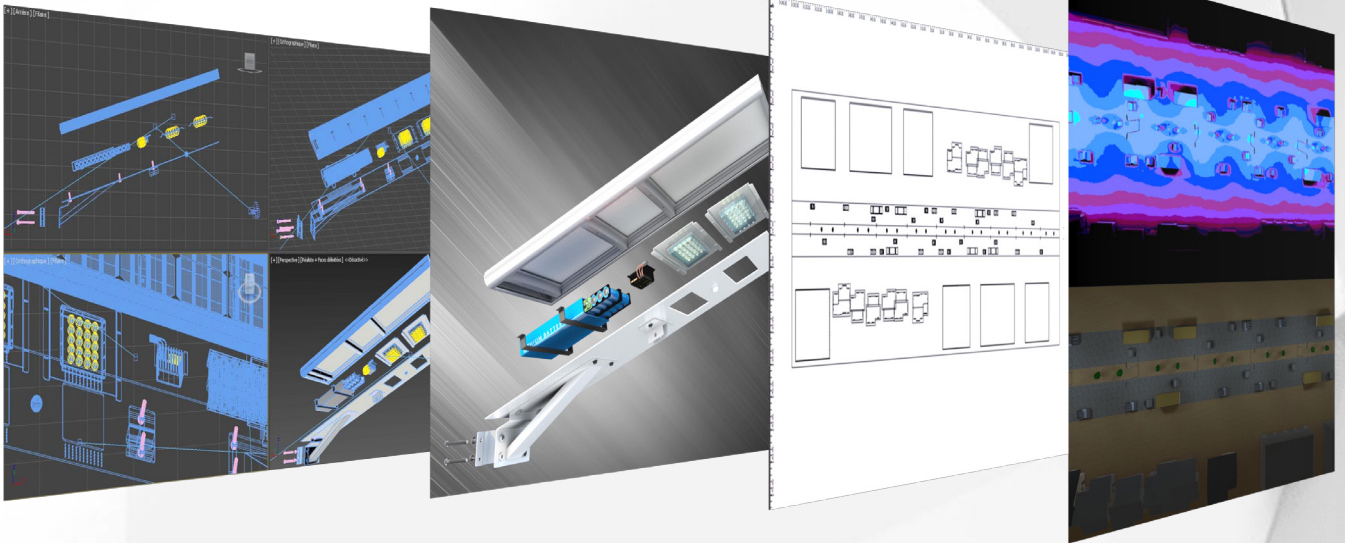

WWW.SOLUX-LIGHT.COM
CONTACT@SOLUX-LIGHT.COM